

Inflatable Conveyor Stops, Guides and Material Handling Solutions.

Conveyor Stops/Brakes/Guides

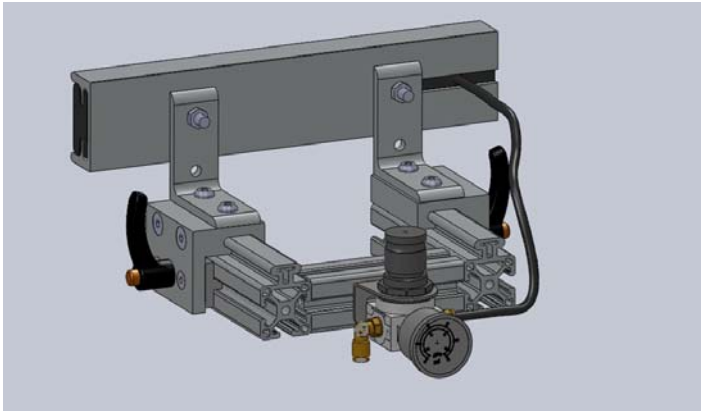

The **Inflata-Stop** is a product designed to safely grip, stop and guide product as it moves along a conveyor line. It is designed to stop product to prevent jams on the conveyor system. They can be designed to grip the product sides or be located underneath the product flow to either lift the product or release the contact between the belt and rollers.

The **Inflata-Stop** is fully adjustable to move in or out away from the product using easy to use linear guides. System includes pressure gage, regulator and connections for easy installation.

Standard sizes are available as well as custom designs. Standard sizes use our DR2 (1.25" wide) and DR3 (2" wide) cross-sections

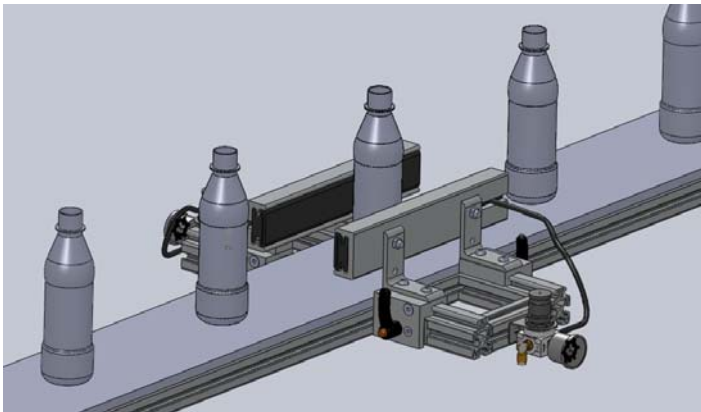

Material Handling

The **Inflata-Grip** is designed for a soft grip on products to safely move or lift. This product is ideal for fragile products such as sand cast molds and other products that need a rubber type grip.

The **Inflata-Grip** can be designed to handle many different forces and weight.

Please contact a Dynamic Rubber Sales Engineer or consult our web site for further information.

www.dynamicrubber.com

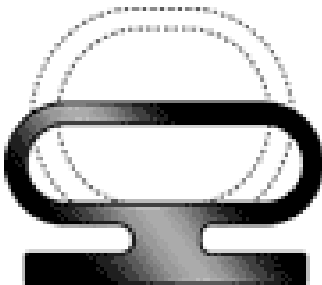

DR2 and DR3 Style Bladder