

ISOMETRIC VIEW

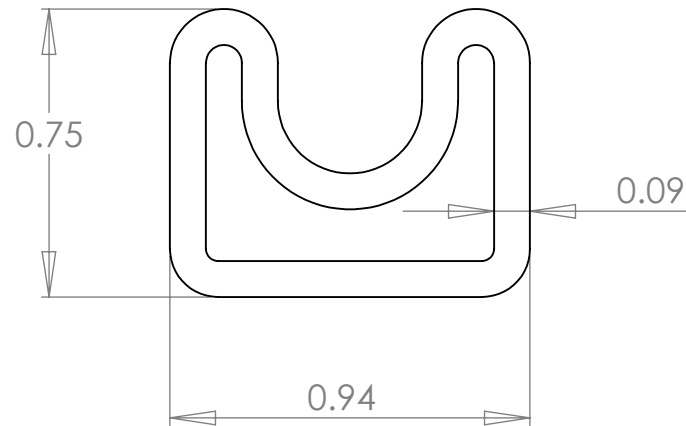

Expansion:
0.375"

Standard Materials:
EPDM

Optional Materials: Setup May Apply
SILICONE
NEOPRENE
NITRILE
BUTYL
FKM

Available Corners: Face/Axial Seals
Not Available - Setup May Apply

Bend Radius:
Min. Dia. = 8" ID

PROPRIETARY AND CONFIDENTIAL
THE INFORMATION CONTAINED IN THIS DRAWING IS THE SOLE PROPERTY OF DYNAMIC RUBBER, INC. ANY REPRODUCTION IN PART OR AS A WHOLE WITHOUT THE WRITTEN PERMISSION OF DYNAMIC RUBBER, INC. IS PROHIBITED.

		UNLESS OTHERWISE SPECIFIED:		NAME	DATE
		DIMENSIONS ARE IN INCHES	DRAWN	T. Thompson	10/16/2009
		TOLERANCES:	CHECKED		
		FRACTIONAL ±	ENG APPR.		
		ANGULAR: MACH ± BEND ±	MFG APPR.		
		TWO PLACE DECIMAL ±	Q.A.		
		THREE PLACE DECIMAL ±	COMMENTS:		
		INTERPRET GEOMETRIC TOLERANCING PER:			
		MATERIAL			
		FINISH			
NEXT ASSY	USED ON				
APPLICATION		DO NOT SCALE DRAWING			



SIZE	DWG. NO.	REV
A	DR82_SEAL	1
SCALE: 1:2	WEIGHT:	SHEET 1 OF 1