

ISOMETRIC VIEW

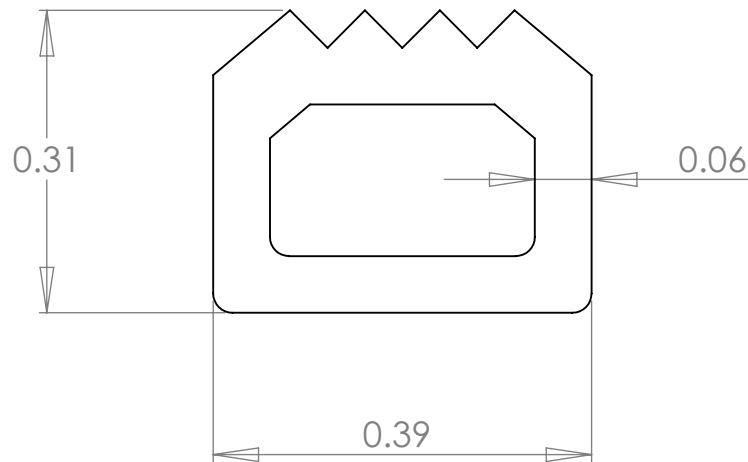

Expansion:
0.0625"

Standard Materials:
EPDM

Optional Materials: Setup May Apply
SILICONE
NEOPRENE
NITRILE
BUTYL
FKM

Available Corners: Face/Axial Seals
Not Available - Setup May Apply

Bend Radius:
Min. Dia. = 4" ID

PROPRIETARY AND CONFIDENTIAL
THE INFORMATION CONTAINED IN THIS DRAWING IS THE SOLE PROPERTY OF DYNAMIC RUBBER, INC. ANY REPRODUCTION IN PART OR AS A WHOLE WITHOUT THE WRITTEN PERMISSION OF DYNAMIC RUBBER, INC. IS PROHIBITED.

		UNLESS OTHERWISE SPECIFIED:	NAME	DATE
		DIMENSIONS ARE IN INCHES TOLERANCES: FRACTIONAL ± ANGULAR: MACH ± BEND ± TWO PLACE DECIMAL ± THREE PLACE DECIMAL ±	DRAWN T. Thompson	11/19/2009
		INTERPRET GEOMETRIC TOLERANCING PER:	CHECKED	
		MATERIAL	ENG APPR.	
		FINISH	MFG APPR.	
NEXT ASSY	USED ON		Q.A.	
APPLICATION		DO NOT SCALE DRAWING	COMMENTS:	



SIZE A	DWG. NO. DR25_SEAL	REV 1
SCALE: 1:2	WEIGHT:	SHEET 1 OF 1